



TBB Cutting Tool

M5 Series

銑削系列  
MILLING TOOLS SERIES

TF45/75/88SN12  
(SN□X1206)

雙面八刃設計確保刀片經濟性  
適用多種材料的粗銑、半精銑  
45度、75度、88度三種主偏角  
適用各大品牌SN□X12系列刀片



團隊切削 行家優選

TEAMCUTTING EXPERT PREFERRED

## TF45SN12 (SN□X1206)

### 8刃雙面45°面銑刀盤

45° Face Mills

SN□X1206系列

SN□X1206 Series

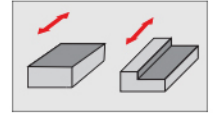
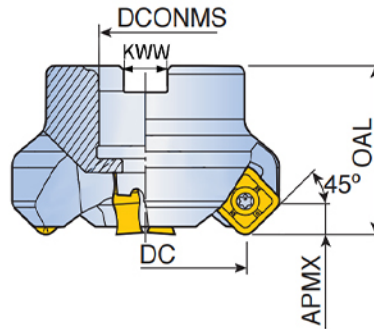

Designation 型號	CICT 齒數	Dimension (mm)/尺寸					Type	Angel 角度	INSERT 刀片
		APMX	DC	KWW	DCONMS	OAL			
TF45SN12-450-22	4	6.5	50	8.4	22	40	A	45°	SN□X1206...
TF45SN12-455-22	4	6.5	55	10.4	22	40	A	45°	SN□X1206...
TF45SN12-563-22	5	6.5	63	10.4	22	40	A	45°	SN□X1206...
TF45SN12-570-22	5	6.5	70	12.4	22	40	A	45°	SN□X1206...
TF45SN12-680-27	6	6.5	80	10.4	27	50	A	45°	SN□X1206...
TF45SN12-7100-32	7	6.5	100	10.4	32	50	A	45°	SN□X1206...
TF45SN12-8125-40	8	6.5	125	12.4	40	55	B	45°	SN□X1206...
TF45SN12-10160-40	10	6.5	160	14.4	40	55	B	45°	SN□X1206...
TF45SN12-12200-60	12	6.5	200	16.4	60	55	C	45°	SN□X1206...
TF45SN12-14250-60	14	6.5	250	16.4	60	55	C	45°	SN□X1206...

## TF75SN12 (SN□X1206)

### 8刃雙面75°面銑刀盤

75° Face Mills

SN□X1206系列

SN□X1206 Series

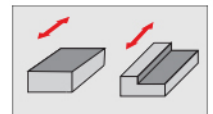
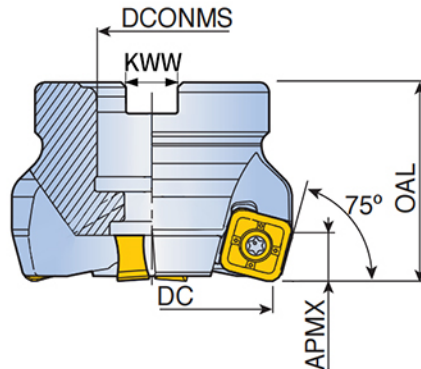

Designation 型號	CICT 齒數	Dimension (mm)/尺寸					Type	Angel 角度	INSERT 刀片
		APMX	DC	KWW	DCONMS	OAL			
TF75SN12-450-22	4	8	50	8.4	22	40	A	75°	SN□X1206...
TF75SN12-455-22	4	8	55	10.4	22	40	A	75°	SN□X1206...
TF75SN12-563-22	5	8	63	10.4	22	40	A	75°	SN□X1206...
TF75SN12-570-22	5	8	70	12.4	22	40	A	75°	SN□X1206...
TF75SN12-680-27	6	8	80	10.4	27	50	A	75°	SN□X1206...
TF75SN12-7100-32	7	8	100	10.4	32	50	A	75°	SN□X1206...
TF75SN12-8125-40	8	8	125	12.4	40	55	B	75°	SN□X1206...
TF75SN12-10160-40	10	8	160	14.4	40	55	B	75°	SN□X1206...
TF75SN12-12200-60	12	8	200	16.4	60	55	C	75°	SN□X1206...
TF75SN12-14250-60	14	8	250	16.4	60	55	C	75°	SN□X1206...

刀片相關資訊請參照第M5-02頁

切削參數請參照第M5-03頁

# TF88SN12 (SN□X1206)

## 8刀雙面88°面銑刀盤

88° Face Mills

SN□X1206系列

SN□X1206 Series

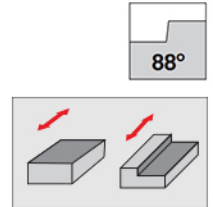
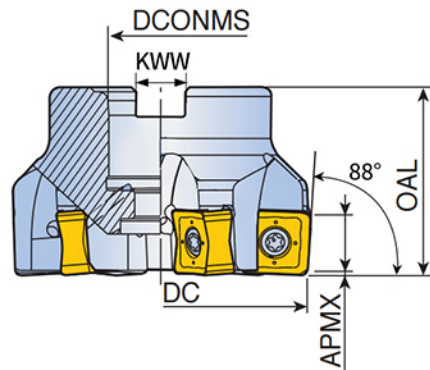

Designation 型號	CIC 齒數	Dimension (mm)/尺寸						Type	Angel 角度	INSERT 刀片
		APMX	DC	KWW	DCONMS	OAL				
TF88SN12-450-22	4	10	50	10.4	22	40	A	88°	SN□X1206...	
TF88SN12-455-22	4	10	55	10.4	22	40	A	88°	SN□X1206...	
TF88SN12-563-22	5	10	63	10.4	22	40	A	88°	SN□X1206...	
TF88SN12-570-22	5	10	70	10.4	22	40	A	88°	SN□X1206...	
TF88SN12-680-27	6	10	80	12.4	27	50	A	88°	SN□X1206...	
TF88SN12-7100-32	7	10	100	14.4	32	50	A	88°	SN□X1206...	
TF88SN12-8125-40	8	10	125	16.4	40	55	B	88°	SN□X1206...	
TF88SN12-10160-40	10	10	160	16.4	40	55	B	88°	SN□X1206...	
TF88SN12-12200-60	12	10	200	25.8	60	55	C	88°	SN□X1206...	
TF88SN12-14250-60	14	10	250	25.8	60	55	C	88°	SN□X1206...	

# SN□X1206 (SN□X12)

## 8刀雙面面銑刀片

Face Mill Inserts

SN□X12系列

SN□X12 Series



**P** 鋼  
**M** 不鏽鋼  
**S** 鈦、鎳

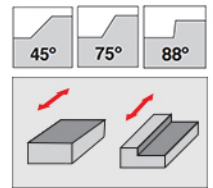
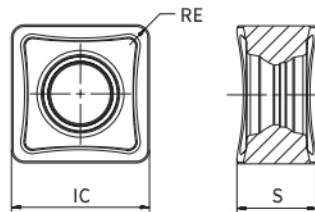

Designation 型號	Dimension (mm)/尺寸						Grade 材質	Use 用途
	IC/大小	S/厚度	RE/圓角	APMX/最大切深	Screw/螺絲	Wrench/扳手		
SNMX120608-MM	12.7	6.98	0.8	6.5-10	TSA-50120-1	TWA-T20	TC3320	<b>P</b> *
							TC5520	<b>M S</b> *
SNMX120612-MM	12.7	6.98	1.2	6.5-10	TSA-50120-1	TWA-T20	TC3320	<b>P</b> *
							TC5520	<b>M S</b> *
SNGX120608-MM	12.7	6.98	0.8	6.5-10	TSA-50120-1	TWA-T20	TC3320	<b>P</b> *
							TC5520	<b>M S</b> *
SNGX120612-MM	12.7	6.98	1.2	6.5-10	TSA-50120-1	TWA-T20	TC3320	<b>P</b> *
							TC5520	<b>M S</b> *

多數SN□X1205/SN□U1205刀片也可以安裝在此系列刀盤上使用。

刀片相關資訊請參照第M5-02頁

切削參數請參照第M5-03頁

# SN□X1206 (SN□X12)

## 8刃雙面面銑刀片

Face Mill Inserts

SN□X12系列

SN□X12 Series

### 切削參數 / Cutting Conditions

ISO	Material/工件材料	Hardness/硬度	Vc (m/min)/切削速度	fz (mm/t)/每齒進給量
<b>P</b>	碳鋼 S45C, S55C ... C45, C55 ...	-300HB	120-300	0.1-0.5
	合金鋼 SCM440, SCr415 ... 42CrMo4 ...	-300HB	80-250	0.1-0.5
	預硬化鋼 NAK80, PX5 ...	30-40HRC	80-200	0.1-0.35
<b>M</b>	不銹鋼 SUS304, SUS316 ... X5CrNi18-9 X5CrNiMo17-12-2 ...	-200HB	80-250	0.1-0.4
<b>K</b>	灰鑄鐵 FC250, FC300 ... 250, 300 ...	150-250HB	120-350	0.1-0.4
	球墨鑄鐵 FCD400 ... 400-15, 600-3 ...	150-250HB	100-300	0.1-0.4
<b>S</b>	鈦合金 Ti-6Al-4V ...	-40HRC	20-50	0.1-0.2
	耐熱合金 Inconel, Hastelloy...	-40HRC	20-50	0.1-0.2
<b>H</b>	淬火鋼	SKD61 ... X40CrMoV5-1 ...	40-50HRC	80-150
		SKD11 ... X153CrMoV12...	50-60HRC	50-70